



## Easy-to-Use, Low-Power, Low-Supply TEMPERATURE SWITCH in MicroPackage

Check for Samples: [TMP302A](#) [TMP302B](#) [TMP302C](#) [TMP302D](#)

### FEATURES

- **LOW POWER:** 15µA (max)
- **SOT563 PACKAGE:** 1,6mm x 1,6mm x 0,6mm
- **TRIP-POINT ACCURACY:** ±0.2°C (typ) from +40°C to +125°C
- **PIN-SELECTABLE TRIP POINTS**
- **OPEN-DRAIN OUTPUT**
- **SELECTABLE HYSTERESIS:** 5°C/10°C
- **LOW SUPPLY VOLTAGE RANGE:** 1.4V to 3.6V

### APPLICATIONS

- **CELL PHONE HANDSETS**
- **PORTABLE MEDIA PLAYERS**
- **CONSUMER ELECTRONICS**
- **SERVERS**
- **POWER-SUPPLY SYSTEMS**
- **DC-DC MODULES**
- **THERMAL MONITORING**
- **ELECTRONIC PROTECTION SYSTEMS**

### DESCRIPTION

The TMP302x is a temperature switch in a micropackage (SOT563). The TMP302x offers low power (15µA max) and ease-of-use through pin-selectable trip points and hysteresis.

These devices require no additional components for operation; they can function independent of microprocessors or microcontrollers.

The TMP302x is available in several different versions. For additional trip points, contact a TI representative.

**TMP302 Available Versions<sup>(1)</sup>**

DEVICE	SELECTABLE TRIP POINTS (°C)
TMP302A	50, 55, 60, 65
TMP302B	70, 75, 80, 85
TMP302C	90, 95, 100, 105
TMP302D	110, 115, 120, 125

(1) For other available trip points, please contact a TI representative.

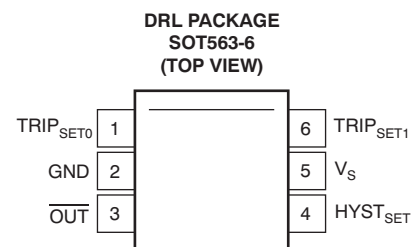
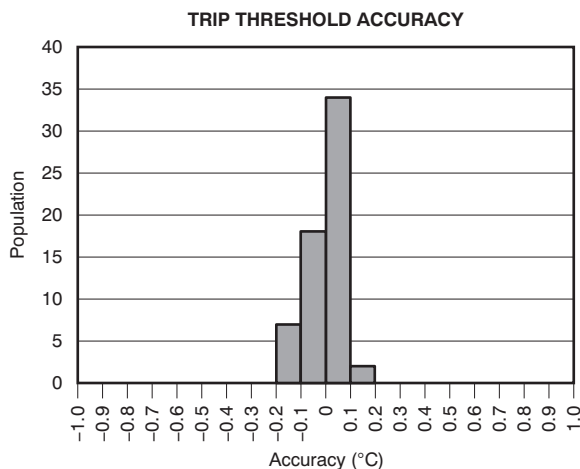

Please be aware that an important notice concerning availability, standard warranty, and use in critical applications of Texas Instruments semiconductor products and disclaimers thereto appears at the end of this data sheet.

All trademarks are the property of their respective owners.



This integrated circuit can be damaged by ESD. Texas Instruments recommends that all integrated circuits be handled with appropriate precautions. Failure to observe proper handling and installation procedures can cause damage.

ESD damage can range from subtle performance degradation to complete device failure. Precision integrated circuits may be more susceptible to damage because very small parametric changes could cause the device not to meet its published specifications.

**PACKAGE INFORMATION<sup>(1)</sup>**

PRODUCT	TRIP POINTS (°C)	PACKAGE-LEAD	PACKAGE DESIGNATOR	PACKAGE MARKING
TMP302A	50, 55, 60, 65	SOT563	DRL	OCP
TMP302B	70, 75, 80, 85	SOT563	DRL	OCT
TMP302C	90, 95, 100, 105	SOT563	DRL	OCR
TMP302D	110, 115, 120, 125	SOT563	DRL	OCS

(1) For the most current package and ordering information see the Package Option Addendum at the end of this document, or see the TI web site at [www.ti.com](http://www.ti.com).

**ABSOLUTE MAXIMUM RATINGS<sup>(1)</sup>**

		TMP302A, TMP302B, TMP302C, TMP302D	UNIT
Supply Voltage		+3.6	V
Input Pins, Voltage	TRIP <sub>SET0</sub> , TRIP <sub>SET1</sub> , HYST <sub>SET</sub>	-0.5 to V <sub>S</sub> + 0.5	V
Output Pin, Voltage	$\overline{\text{OUT}}$	-0.5 to +3.6	V
Output Pin, Current	$\overline{\text{OUT}}$	10	mA
Operating Temperature		-55 to +130	°C
Storage Temperature Range		-60 to +150	°C
Junction Temperature Range		+150	°C
ESD Rating:	Human Body Model (HBM)	2000	V
	Charged-Device Model (CDM)	1000	V
	Machine Model (MM)	200	V

(1) Stresses above these ratings may cause permanent damage. Exposure to absolute maximum conditions for extended periods may degrade device reliability. These are stress ratings only, and functional operation of the device at these or any other conditions beyond those specified is not supported.

## ELECTRICAL CHARACTERISTICS

 At  $T_A = -40^\circ\text{C}$  to  $+125^\circ\text{C}$ , and  $V_S = +1.4\text{V}$  to  $+3.6\text{V}$ , unless otherwise noted.

PARAMETER	TEST CONDITIONS	TMP302 (1)			UNIT
		MIN	TYP	MAX	
<b>TEMPERATURE MEASUREMENT</b>					
Trip Point Accuracy vs. Supply	$T_A = +40^\circ\text{C}$ to $+125^\circ\text{C}$		$\pm 0.2$	$\pm 2$	$^\circ\text{C}$
Trip Point Hysteresis	$\text{HYST}_{\text{SET}} = \text{GND}$ $\text{HYST}_{\text{SET}} = V_S$		$\pm 0.2$ 5 10	$\pm 0.5$ $^\circ\text{C}$ $^\circ\text{C}$	$^\circ\text{C/V}$ $^\circ\text{C}$ $^\circ\text{C}$
<b>TEMPERATURE TRIP POINT SET</b>					
Temperature Trip Point Set	$\text{TRIP}_{\text{SET1}} = \text{GND}, \text{TRIP}_{\text{SET0}} = \text{GND}$ $\text{TRIP}_{\text{SET1}} = \text{GND}, \text{TRIP}_{\text{SET0}} = V_S$ $\text{TRIP}_{\text{SET1}} = V_S, \text{TRIP}_{\text{SET0}} = \text{GND}$ $\text{TRIP}_{\text{SET1}} = V_S, \text{TRIP}_{\text{SET0}} = V_S$		Default Default + 5 Default + 10 Default + 15	$^\circ\text{C}$ $^\circ\text{C}$ $^\circ\text{C}$ $^\circ\text{C}$	$^\circ\text{C}$ $^\circ\text{C}$ $^\circ\text{C}$ $^\circ\text{C}$
<b>HYSTERESIS SET INPUT</b>					
Input Logic Levels:					
$V_{\text{IH}}$		$0.7 \times (V_S)$		$V_S$	V
$V_{\text{IL}}$		-0.5		$0.3 \times (V_S)$	V
Input Current:					
$I_{\text{IN}}$	$0 < V_{\text{IN}} < 3.6\text{V}$			1	$\mu\text{A}$
<b>DIGITAL OUTPUT</b>					
Output Logic Level:					
$V_{\text{OL}}$	$V_S > 2\text{V}, I_{\text{OL}} = 3\text{mA}$ $V_S < 2\text{V}, I_{\text{OL}} = 3\text{mA}$	0 0		0.4 $0.2 \times (V_S)$	V V
<b>POWER SUPPLY</b>					
Operating Supply Range		1.4		3.6	V
Quiescent Current	$I_Q$ $V_S = 3.3\text{V}, T_A = +50^\circ\text{C}$		8 7	15	$\mu\text{A}$ $\mu\text{A}$
<b>TEMPERATURE RANGE</b>					
Specified Range		-40		+125	$^\circ\text{C}$
Operating Range		-55		+130	$^\circ\text{C}$
Thermal Resistance	$\theta_{\text{JA}}$				
SOT563	JEDEC Low-K Board		+260		$^\circ\text{C/W}$

 (1) 100% of all units are production tested at  $T_A = +25^\circ\text{C}$ . Over temperature specifications are specified by design.

### TYPICAL CHARACTERISTICS

At  $T_A = +25^\circ\text{C}$  and  $V_S = 3.3\text{V}$ , unless otherwise noted.

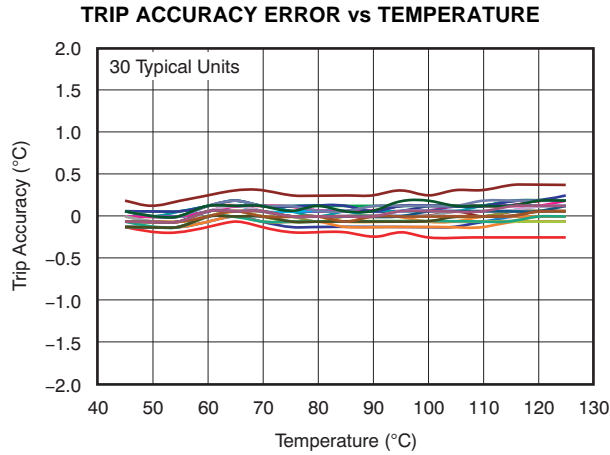

Figure 1.

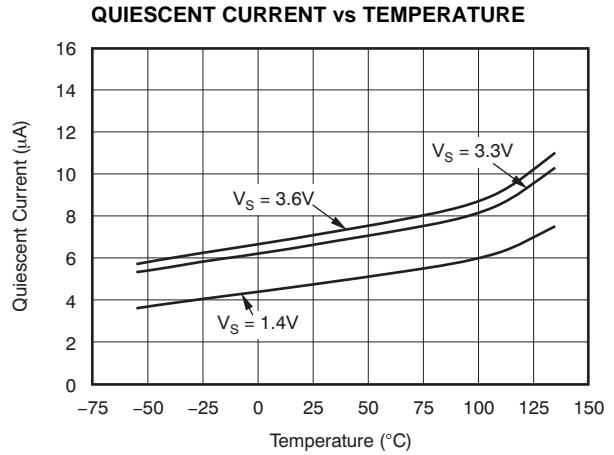

Figure 2.

#### TEMPERATURE STEP RESPONSE IN PERFLUORINATED FLUID AT +100°C vs TIME

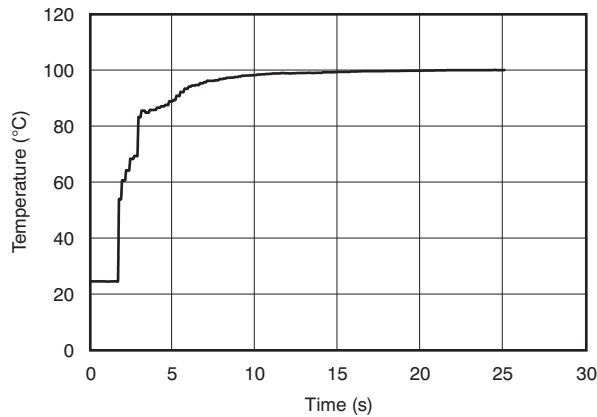

Figure 3.

#### THERMAL STEP RESPONSE IN AIR AT +100°C vs TIME

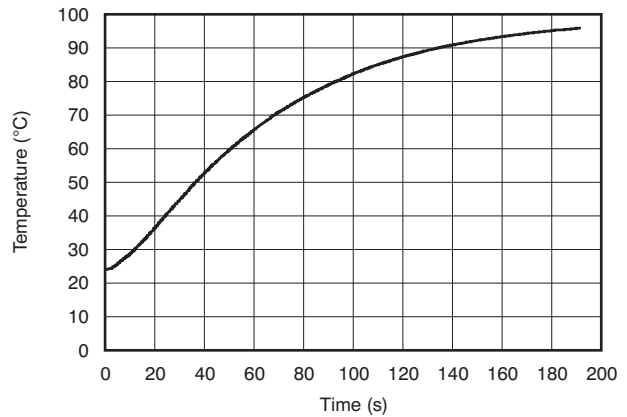

Figure 4.

#### TRIP THRESHOLD ACCURACY

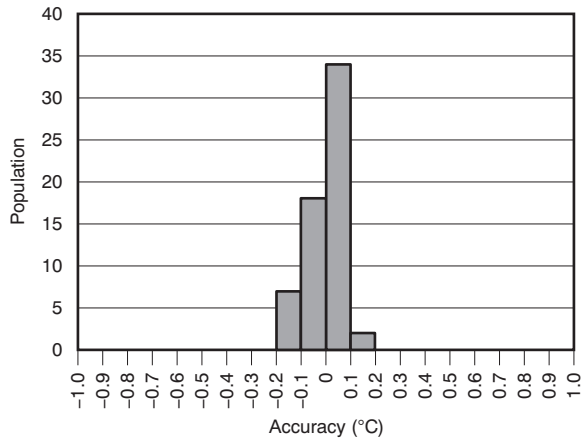

Figure 5.

#### OUTPUT LOGIC LEVEL LOW $V_{OL}$ vs TEMPERATURE

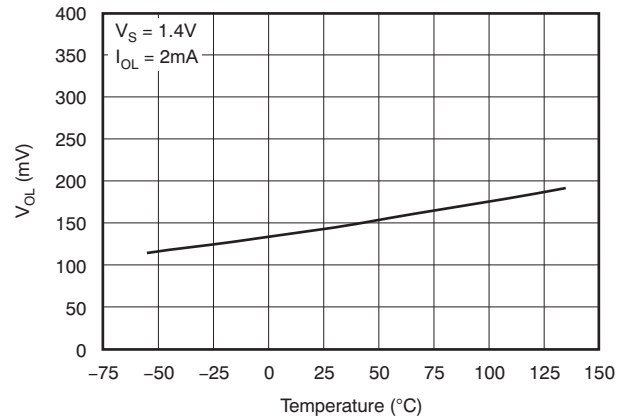
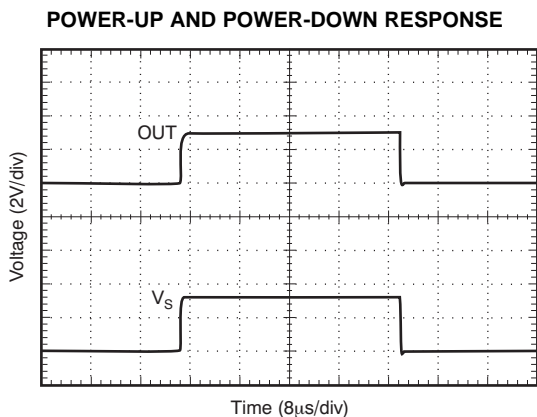

Figure 6.

**TYPICAL CHARACTERISTICS (continued)**

At  $T_A = +25^\circ\text{C}$  and  $V_S = 3.3\text{V}$ , unless otherwise noted.



**Figure 7.**

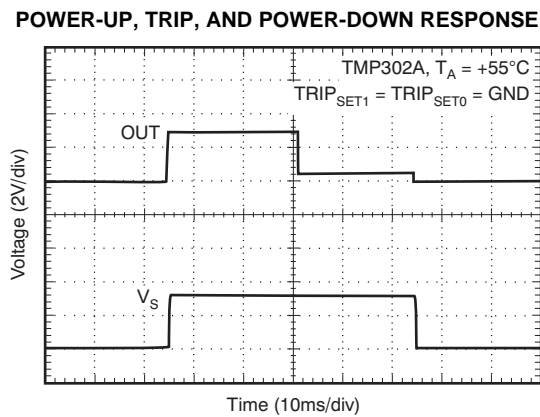

**Figure 8.**

## APPLICATION INFORMATION

The TMP302 temperature switch is optimal for ultralow-power battery applications that require accurate trip thresholds. The trip thresholds are programmable to four different settings using the TRIP<sub>SET1</sub> and TRIP<sub>SET0</sub> pins. Table 1 shows the pin settings versus trip points.

**Table 1. Trip Point vs TRIP<sub>SET1</sub> and TRIP<sub>SET0</sub>**

TRIP <sub>SET1</sub>	TRIP <sub>SET0</sub>	TMP302A	TMP302B	TMP302C	TMP302D
GND	GND	+50°C	+70°C	+90°C	+110°C
GND	V <sub>S</sub>	+55°C	+75°C	+95°C	+115°C
V <sub>S</sub>	GND	+60°C	+80°C	+100°C	+120°C
V <sub>S</sub>	V <sub>S</sub>	+65°C	+85°C	+105°C	+125°C

The typical thermal response time for the TMP302 is about 250ms. This period is the minimum time frame that it takes for the open-drain output ( $\overline{\text{OUT}}$ ) to change its state from low to high (or vice-versa) while the device is active. A maximum low output voltage is defined as a voltage level equivalent to  $0.2 \times V_S$ ; likewise, a minimum high output voltage is defined as  $0.8 \times V_S$ . It is important to note that an exception to the nominal 250ms response time occurs on power up—in this case, it is possible to achieve a thermal response in as little as 35ms.

### CONFIGURING THE TMP302

The TMP302 is simple to configure. The only external components that it requires are a bypass capacitor and pull-up resistor. Power-supply bypassing is strongly recommended; use a 0.1 $\mu$ F capacitor placed as close as possible to the supply pin. To minimize the internal power dissipation of the TMP302, use a pull-up resistor value greater than 10k $\Omega$  from  $\overline{\text{OUT}}$  to V<sub>S</sub>. Refer to Table 1 for trip point temperature configuration. The TRIP<sub>SET</sub> pins can be toggled dynamically; however, the voltage of these pins must not exceed V<sub>S</sub>. To ensure a proper logic high, the voltage must not drop below  $0.7V \times V_S$ .

### HYST<sub>SET</sub>

If the temperature trip threshold is crossed, the open-drain output ( $\overline{\text{OUT}}$ ) goes low and does not return to its original high state (that is, V<sub>S</sub>) until the temperature returns to a value within a hysteresis window set by the HYST<sub>SET</sub> pin. The HYST<sub>SET</sub> pin allows the user to choose between a +5°C and a +10°C hysteresis window. Table 2 shows the hysteresis window that corresponds to the HYST<sub>SET</sub> setting.

**Table 2. HYST<sub>SET</sub> Window**

HYST <sub>SET</sub>	THRESHOLD HYSTERESIS
GND	+5°C
V <sub>S</sub>	+10°C

For the specific case of the TMP302A, if the HYST<sub>SET</sub> pin is set to +10°C (that is, connected to V<sub>S</sub>) and the device is configured with a +60°C trip point (TRIP<sub>SET1</sub> = V<sub>S</sub>, TRIP<sub>SET0</sub> = GND), once this threshold is exceeded the output does not return to its original high state until it reaches +50°C. This case is more clearly illustrated in Figure 9.

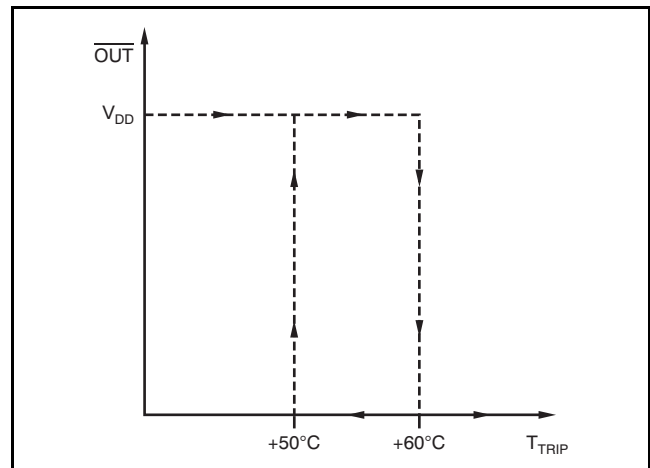

**Figure 9. TMP302A; HYST<sub>SET</sub> = V<sub>S</sub>; TRIP<sub>SET1</sub> = V<sub>S</sub>, TRIP<sub>SET0</sub> = GND**

**PACKAGING INFORMATION**

Orderable Device	Status <sup>(1)</sup>	Package Type	Package Drawing	Pins	Package Qty	Eco Plan <sup>(2)</sup>	Lead/Ball Finish	MSL Peak Temp <sup>(3)</sup>
TMP302ADRLR	ACTIVE	SOT	DRL	6	4000	Green (RoHS & no Sb/Br)	CU NIPDAU	Level-1-260C-UNLIM
TMP302ADRLT	ACTIVE	SOT	DRL	6	250	Green (RoHS & no Sb/Br)	CU NIPDAU	Level-1-260C-UNLIM
TMP302BDRLR	ACTIVE	SOT	DRL	6	4000	Green (RoHS & no Sb/Br)	CU NIPDAU	Level-1-260C-UNLIM
TMP302BDRLT	ACTIVE	SOT	DRL	6	250	Green (RoHS & no Sb/Br)	CU NIPDAU	Level-1-260C-UNLIM
TMP302CDRLR	ACTIVE	SOT	DRL	6	4000	Green (RoHS & no Sb/Br)	CU NIPDAU	Level-1-260C-UNLIM
TMP302CDRLT	ACTIVE	SOT	DRL	6	250	Green (RoHS & no Sb/Br)	CU NIPDAU	Level-1-260C-UNLIM
TMP302DDRLR	ACTIVE	SOT	DRL	6	4000	Green (RoHS & no Sb/Br)	CU NIPDAU	Level-1-260C-UNLIM
TMP302DDRLT	ACTIVE	SOT	DRL	6	250	Green (RoHS & no Sb/Br)	CU NIPDAU	Level-1-260C-UNLIM

<sup>(1)</sup> The marketing status values are defined as follows:

**ACTIVE:** Product device recommended for new designs.

**LIFEBUY:** TI has announced that the device will be discontinued, and a lifetime-buy period is in effect.

**NRND:** Not recommended for new designs. Device is in production to support existing customers, but TI does not recommend using this part in a new design.

**PREVIEW:** Device has been announced but is not in production. Samples may or may not be available.

**OBSELETE:** TI has discontinued the production of the device.

<sup>(2)</sup> Eco Plan - The planned eco-friendly classification: Pb-Free (RoHS), Pb-Free (RoHS Exempt), or Green (RoHS & no Sb/Br) - please check <http://www.ti.com/productcontent> for the latest availability information and additional product content details.

**TBD:** The Pb-Free/Green conversion plan has not been defined.

**Pb-Free (RoHS):** TI's terms "Lead-Free" or "Pb-Free" mean semiconductor products that are compatible with the current RoHS requirements for all 6 substances, including the requirement that lead not exceed 0.1% by weight in homogeneous materials. Where designed to be soldered at high temperatures, TI Pb-Free products are suitable for use in specified lead-free processes.

**Pb-Free (RoHS Exempt):** This component has a RoHS exemption for either 1) lead-based flip-chip solder bumps used between the die and package, or 2) lead-based die adhesive used between the die and leadframe. The component is otherwise considered Pb-Free (RoHS compatible) as defined above.

**Green (RoHS & no Sb/Br):** TI defines "Green" to mean Pb-Free (RoHS compatible), and free of Bromine (Br) and Antimony (Sb) based flame retardants (Br or Sb do not exceed 0.1% by weight in homogeneous material)

<sup>(3)</sup> MSL, Peak Temp. -- The Moisture Sensitivity Level rating according to the JEDEC industry standard classifications, and peak solder temperature.

**Important Information and Disclaimer:**The information provided on this page represents TI's knowledge and belief as of the date that it is provided. TI bases its knowledge and belief on information provided by third parties, and makes no representation or warranty as to the accuracy of such information. Efforts are underway to better integrate information from third parties. TI has taken and continues to take reasonable steps to provide representative and accurate information but may not have conducted destructive testing or chemical analysis on incoming materials and chemicals. TI and TI suppliers consider certain information to be proprietary, and thus CAS numbers and other limited information may not be available for release.

In no event shall TI's liability arising out of such information exceed the total purchase price of the TI part(s) at issue in this document sold by TI to Customer on an annual basis.

**TAPE AND REEL INFORMATION**
**REEL DIMENSIONS**

**TAPE DIMENSIONS**

A0	Dimension designed to accommodate the component width
B0	Dimension designed to accommodate the component length
K0	Dimension designed to accommodate the component thickness
W	Overall width of the carrier tape
P1	Pitch between successive cavity centers

**TAPE AND REEL INFORMATION**

\*All dimensions are nominal

Device	Package Type	Package Drawing	Pins	SPQ	Reel Diameter (mm)	Reel Width W1 (mm)	A0 (mm)	B0 (mm)	K0 (mm)	P1 (mm)	W (mm)	Pin1 Quadrant
TMP302ADRLR	SOT	DRL	6	4000	180.0	9.5	1.78	1.78	0.69	4.0	8.0	Q2
TMP302ADRLR	SOT	DRL	6	4000	180.0	8.4	1.98	1.78	0.69	4.0	8.0	Q3
TMP302ADRLT	SOT	DRL	6	250	180.0	8.4	1.98	1.78	0.69	4.0	8.0	Q3
TMP302ADRLT	SOT	DRL	6	250	180.0	9.5	1.78	1.78	0.69	4.0	8.0	Q2
TMP302BDRLR	SOT	DRL	6	4000	180.0	8.4	1.98	1.78	0.69	4.0	8.0	Q3
TMP302BDRLR	SOT	DRL	6	4000	180.0	9.5	1.78	1.78	0.69	4.0	8.0	Q2
TMP302BDRLT	SOT	DRL	6	250	180.0	9.5	1.78	1.78	0.69	4.0	8.0	Q2
TMP302BDRLT	SOT	DRL	6	250	180.0	8.4	1.98	1.78	0.69	4.0	8.0	Q3
TMP302CDRLR	SOT	DRL	6	4000	180.0	8.4	1.98	1.78	0.69	4.0	8.0	Q3
TMP302CDRLR	SOT	DRL	6	4000	180.0	9.5	1.78	1.78	0.69	4.0	8.0	Q2
TMP302CDRLT	SOT	DRL	6	250	180.0	9.5	1.78	1.78	0.69	4.0	8.0	Q2
TMP302DDRLR	SOT	DRL	6	4000	180.0	9.5	1.78	1.78	0.69	4.0	8.0	Q2
TMP302DDRLR	SOT	DRL	6	4000	180.0	8.4	1.98	1.78	0.69	4.0	8.0	Q3
TMP302DDRLT	SOT	DRL	6	250	180.0	8.4	1.98	1.78	0.69	4.0	8.0	Q3
TMP302DDRLT	SOT	DRL	6	250	180.0	9.5	1.78	1.78	0.69	4.0	8.0	Q2



**TAPE AND REEL BOX DIMENSIONS**

\*All dimensions are nominal

Device	Package Type	Package Drawing	Pins	SPQ	Length (mm)	Width (mm)	Height (mm)
TMP302ADRLR	SOT	DRL	6	4000	180.0	180.0	30.0
TMP302ADRLR	SOT	DRL	6	4000	202.0	201.0	28.0
TMP302ADRLT	SOT	DRL	6	250	202.0	201.0	28.0
TMP302ADRLT	SOT	DRL	6	250	180.0	180.0	30.0
TMP302BDRLR	SOT	DRL	6	4000	202.0	201.0	28.0
TMP302BDRLR	SOT	DRL	6	4000	180.0	180.0	30.0
TMP302BDRLT	SOT	DRL	6	250	180.0	180.0	30.0
TMP302BDRLT	SOT	DRL	6	250	202.0	201.0	28.0
TMP302CDRLR	SOT	DRL	6	4000	202.0	201.0	28.0
TMP302CDRLR	SOT	DRL	6	4000	180.0	180.0	30.0
TMP302CDRLT	SOT	DRL	6	250	180.0	180.0	30.0
TMP302DDRLR	SOT	DRL	6	4000	180.0	180.0	30.0
TMP302DDRLR	SOT	DRL	6	4000	202.0	201.0	28.0
TMP302DDRLT	SOT	DRL	6	250	202.0	201.0	28.0
TMP302DDRLT	SOT	DRL	6	250	180.0	180.0	30.0

DRL (R-PDSO-N6)

PLASTIC SMALL OUTLINE

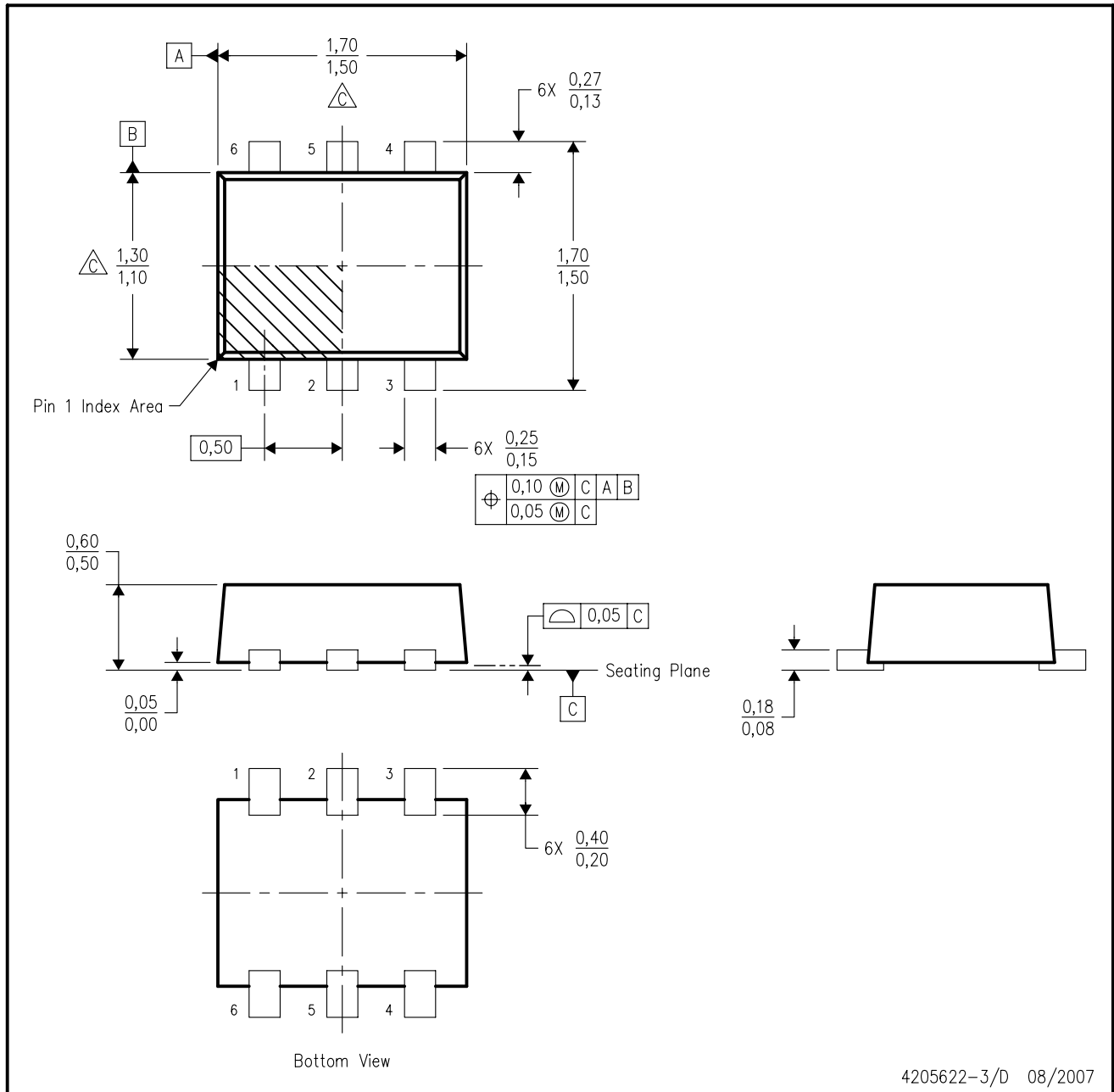

- NOTES:
- A. All linear dimensions are in millimeters. Dimensioning and tolerancing per ASME Y14.5M-1994.
  - B. This drawing is subject to change without notice.
  - C. Body dimensions do not include mold flash, interlead flash, protrusions, or gate burrs. Mold flash, interlead flash, protrusions, or gate burrs shall not exceed 0,15 per end or side.
  - D. JEDEC package registration is pending.

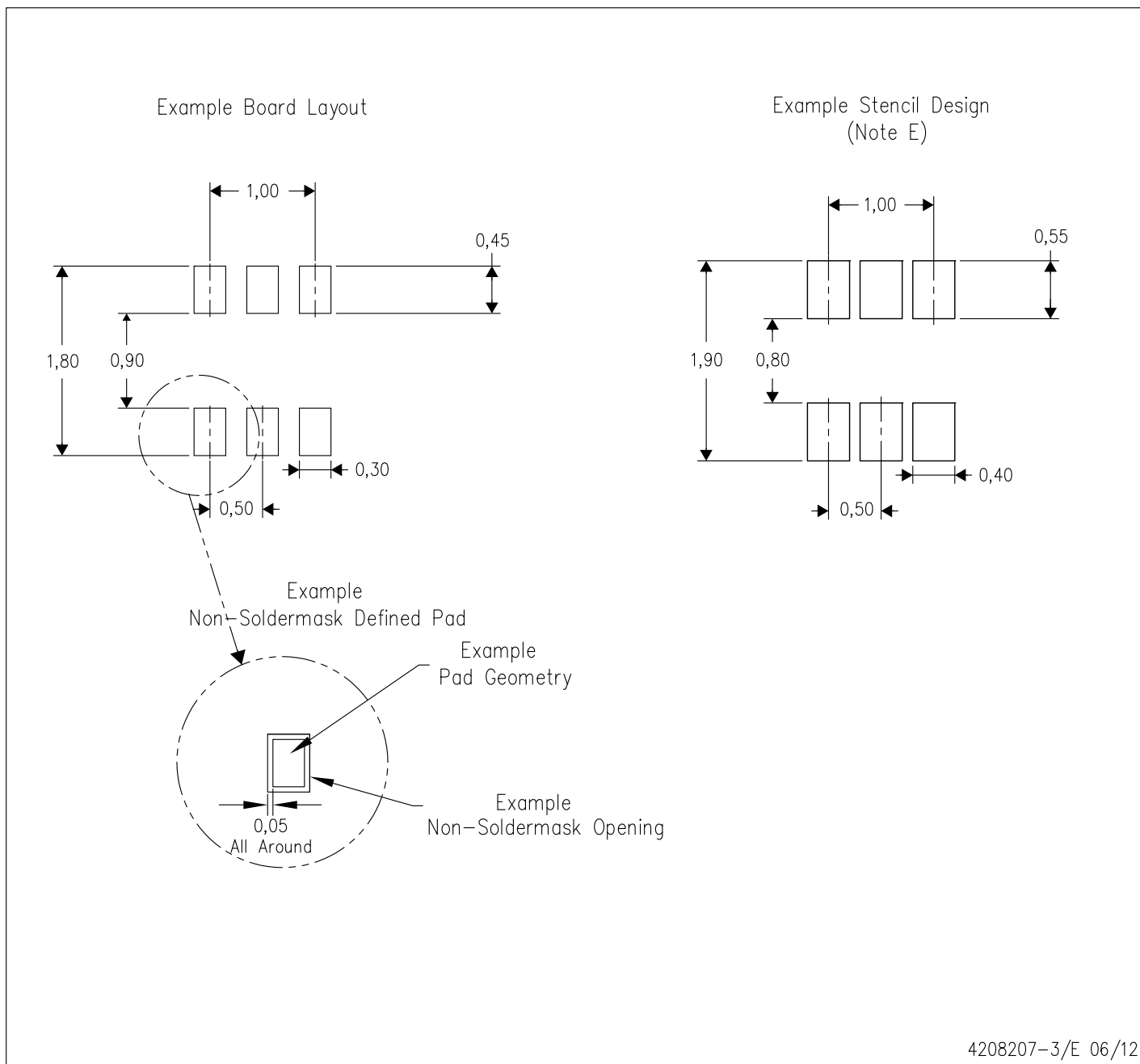

- NOTES:
- A. All linear dimensions are in millimeters.
  - B. This drawing is subject to change without notice.
  - C. Publication IPC-7351 is recommended for alternate designs.
  - D. Customers should contact their board fabrication site for minimum solder mask web tolerances between signal pads.
  - E. Maximum stencil thickness 0,127 mm (5 mils). All linear dimensions are in millimeters.
  - F. Laser cutting apertures with trapezoidal walls and also rounding corners will offer better paste release. Customers should contact their board assembly site for stencil design recommendations. Refer to IPC 7525 for stencil design considerations.
  - G. Side aperture dimensions over-print land for acceptable area ratio > 0.66. Customer may reduce side aperture dimensions if stencil manufacturing process allows for sufficient release at smaller opening.

## IMPORTANT NOTICE

Texas Instruments Incorporated and its subsidiaries (TI) reserve the right to make corrections, enhancements, improvements and other changes to its semiconductor products and services per JESD46C and to discontinue any product or service per JESD48B. Buyers should obtain the latest relevant information before placing orders and should verify that such information is current and complete. All semiconductor products (also referred to herein as "components") are sold subject to TI's terms and conditions of sale supplied at the time of order acknowledgment.

TI warrants performance of its components to the specifications applicable at the time of sale, in accordance with the warranty in TI's terms and conditions of sale of semiconductor products. Testing and other quality control techniques are used to the extent TI deems necessary to support this warranty. Except where mandated by applicable law, testing of all parameters of each component is not necessarily performed.

TI assumes no liability for applications assistance or the design of Buyers' products. Buyers are responsible for their products and applications using TI components. To minimize the risks associated with Buyers' products and applications, Buyers should provide adequate design and operating safeguards.

TI does not warrant or represent that any license, either express or implied, is granted under any patent right, copyright, mask work right, or other intellectual property right relating to any combination, machine, or process in which TI components or services are used. Information published by TI regarding third-party products or services does not constitute a license to use such products or services or a warranty or endorsement thereof. Use of such information may require a license from a third party under the patents or other intellectual property of the third party, or a license from TI under the patents or other intellectual property of TI.

Reproduction of significant portions of TI information in TI data books or data sheets is permissible only if reproduction is without alteration and is accompanied by all associated warranties, conditions, limitations, and notices. TI is not responsible or liable for such altered documentation. Information of third parties may be subject to additional restrictions.

Resale of TI components or services with statements different from or beyond the parameters stated by TI for that component or service voids all express and any implied warranties for the associated TI component or service and is an unfair and deceptive business practice. TI is not responsible or liable for any such statements.

Buyer acknowledges and agrees that it is solely responsible for compliance with all legal, regulatory and safety-related requirements concerning its products, and any use of TI components in its applications, notwithstanding any applications-related information or support that may be provided by TI. Buyer represents and agrees that it has all the necessary expertise to create and implement safeguards which anticipate dangerous consequences of failures, monitor failures and their consequences, lessen the likelihood of failures that might cause harm and take appropriate remedial actions. Buyer will fully indemnify TI and its representatives against any damages arising out of the use of any TI components in safety-critical applications.

In some cases, TI components may be promoted specifically to facilitate safety-related applications. With such components, TI's goal is to help enable customers to design and create their own end-product solutions that meet applicable functional safety standards and requirements. Nonetheless, such components are subject to these terms.

No TI components are authorized for use in FDA Class III (or similar life-critical medical equipment) unless authorized officers of the parties have executed a special agreement specifically governing such use.

Only those TI components which TI has specifically designated as military grade or "enhanced plastic" are designed and intended for use in military/aerospace applications or environments. Buyer acknowledges and agrees that any military or aerospace use of TI components which have **not** been so designated is solely at the Buyer's risk, and that Buyer is solely responsible for compliance with all legal and regulatory requirements in connection with such use.

TI has specifically designated certain components which meet ISO/TS16949 requirements, mainly for automotive use. Components which have not been so designated are neither designed nor intended for automotive use; and TI will not be responsible for any failure of such components to meet such requirements.

### Products

Audio	<a href="http://www.ti.com/audio">www.ti.com/audio</a>
Amplifiers	<a href="http://amplifier.ti.com">amplifier.ti.com</a>
Data Converters	<a href="http://dataconverter.ti.com">dataconverter.ti.com</a>
DLP® Products	<a href="http://www.dlp.com">www.dlp.com</a>
DSP	<a href="http://dsp.ti.com">dsp.ti.com</a>
Clocks and Timers	<a href="http://www.ti.com/clocks">www.ti.com/clocks</a>
Interface	<a href="http://interface.ti.com">interface.ti.com</a>
Logic	<a href="http://logic.ti.com">logic.ti.com</a>
Power Mgmt	<a href="http://power.ti.com">power.ti.com</a>
Microcontrollers	<a href="http://microcontroller.ti.com">microcontroller.ti.com</a>
RFID	<a href="http://www.ti-rfid.com">www.ti-rfid.com</a>
OMAP Mobile Processors	<a href="http://www.ti.com/omap">www.ti.com/omap</a>
Wireless Connectivity	<a href="http://www.ti.com/wirelessconnectivity">www.ti.com/wirelessconnectivity</a>

### Applications

Automotive and Transportation	<a href="http://www.ti.com/automotive">www.ti.com/automotive</a>
Communications and Telecom	<a href="http://www.ti.com/communications">www.ti.com/communications</a>
Computers and Peripherals	<a href="http://www.ti.com/computers">www.ti.com/computers</a>
Consumer Electronics	<a href="http://www.ti.com/consumer-apps">www.ti.com/consumer-apps</a>
Energy and Lighting	<a href="http://www.ti.com/energy">www.ti.com/energy</a>
Industrial	<a href="http://www.ti.com/industrial">www.ti.com/industrial</a>
Medical	<a href="http://www.ti.com/medical">www.ti.com/medical</a>
Security	<a href="http://www.ti.com/security">www.ti.com/security</a>
Space, Avionics and Defense	<a href="http://www.ti.com/space-avionics-defense">www.ti.com/space-avionics-defense</a>
Video and Imaging	<a href="http://www.ti.com/video">www.ti.com/video</a>

**TI E2E Community** [e2e.ti.com](http://e2e.ti.com)